

**REVISED RULES AND STANDARDS FOR ECONOMIC AND  
SOCIALIZED HOUSING PROJECTS TO IMPLEMENT  
BATAS PAMBANSA BLG. 220**

Pursuant to Section 3 of BP 220, the Housing and Land Use Regulatory Board is authorized to establish and promulgate two levels of standards and technical requirements for the development of economic and socialized housing projects/units in urban and rural areas from those provided in PD 957, PD 1216, PD 1096, and PD 1185, hence the following rules are hereby promulgated.

**RULE I  
GENERAL PROVISIONS**

**Section 1. Scope of Application**

These rules and standards shall apply to the development of economic and socialized housing projects in urban and rural areas as defined in Section 2 of BP Blg. 220. They shall apply to the development of either a house and lot or a house or lot only.

**Section 2. Declaration of Policies**

It is a policy of the government to promote and encourage the development of economic and socialized housing projects, primarily by the private sector in order to make available adequate economic and socialized housing units for average and low income earners in urban and rural areas.

**RULE II  
MINIMUM DESIGN STANDARDS AND REQUIREMENTS  
FOR ECONOMIC AND SOCIALIZED HOUSING PROJECTS**

**Section 3. Compliance with Standards and Guidelines**

Development of economic and socialized housing projects shall be in accordance with the minimum design standards herein set forth.

**Section 4. Basis and Objectives of the Minimum Design Standards**

The minimum design standards set forth herein are intended to provide minimum requirements within the generally accepted levels of safety, health and ecological considerations. Variations, however are also possible, as may be based on some specific regional, cultural and economic setting, e.g., building materials, space requirement and usage. This minimum design standards encourages the use of duly accredited indigenous materials and technology such as innovative design and systems, modular systems and components among others. The parameters used in formulating these Design Standards are:

- A. Protection and safety of life, limb, property and general public welfare.**

**B. Basic needs of human settlements, enumerated in descending order as follows:**

1. Water
2. Movement and circulation
3. Storm drainage
4. Solid and liquid waste disposal
5. Park/playground
6. Power

The provision of these basic needs shall be based on the actual setting within which the project site is located.

**C. Affordability levels of target market**

Affordable cost - refers to the most reasonable price of land and shelter based on the needs and financial capability of Program Beneficiaries and Appropriate Financing Schemes (RA 7279)

**D. Location**

Both economic and socialized housing projects shall be located within suitable site for housing and outside potential hazard prone and protection areas.

## **Section 5. Technical Guidelines and Standards for Subdivisions**

In determining whether an economic and socialized housing shall be allowed, the following guidelines shall be considered.

**A. Site Criteria**

**1. Availability of basic needs**

The prioritized basic needs cited earlier shall preferably be available with reasonable distance from the project site, but where these are not available, the same shall be provided for by the developer.

**2. Conformity with the Zoning Ordinance or Land Use Plan of the City/Municipality**

Generally, housing projects should conform with the zoning ordinance of the city/municipality where they are located thus shall be in suitable sites for housing. However, where there is no zoning ordinance or land use plan, the predominant land use principle and site suitability factors cited herein shall be used in determining suitability of a project to a site.

Furthermore, if the project is undoubtedly supportive of other land uses and activities (e.g., housing for industrial workers) said project shall be allowed.

*g*

*g*

### **3. Physical Suitability**

A potential site must have characteristics assuring healthful, safe and environmentally sound community life. It shall be stable enough to accommodate foundation load without excessive site works. Critical areas (e.g., areas subject to flooding, land slides and stress) must be avoided.

### **4. Accessibility**

The site must be served by a road that is readily accessible to public transportation lines. Said access road shall conform to the standards set herein of these Rules to accommodate expected demand caused by the development of the area. In no case shall a subdivision project be approved without necessary access road/right-of-way constructed either by the developer or the Local Government Unit.

## **B. Planning Considerations**

### **1. Area Planning**

Project design should consider not only the reduction of cost of development to a minimum but also the provision for possible future improvement or expansion, as in the prescription of lot sizes, right-of-way of roads, open space, allocation of areas for common uses and facilities.

Land allocation and alignment of the various utilities (roads, drainage, power and water) of the subdivision shall be integrated with those of existing networks as well as projects outside the boundaries of the project site, e.g. access roads set forth herein and should follow the standard specifications of the Department of Public Works and Highways (DPWH).

### **2. Site Preservation/Alteration**

#### **a. Slope**

The finished grade shall have a desired slope to allow rain water to be channeled into street drains. Where cut and fill is necessary, an appropriate grade shall be attained to prevent any depression in the area.

Grading and ditching shall be executed in a manner that will prevent erosion or flooding of adjoining properties.

#### **b. Preservation of Site Assets**

Suitable trees with a caliper diameter of 200 millimeters or more, shrubs and desirable ground cover shall be preserved. Where a good quality top soil exists in the site, it shall not be removed and shall be preserved for finishing grades of yards, playgrounds, parks and garden area.



### c. Ground Cover

Grass, shrubs, plants and other landscaping materials used for ground cover shall be of variety appropriate for its intended use and location. They shall be so planted as to allow complete and permanent cover of the area.

### 3. Easements

Subdivision projects shall observe and conform to the provisions of easements as may be required by:

- a. Chapter IV, Section 51 of the Water Code of the Philippines on water bodies
- b. National Power Corporation (NPC) on transmission lines
- c. Fault traces as identified by PHIVOLCS per Resolution No. 515, series of 1992
- d. Right-of-way of other public companies and other entities
- e. For projects abutting national roads (primary roads) adequate easement shall be provided for road including loading and unloading as may be required by national/local government units.
- f. Other related laws

### 4. Circulation

- a. Depending on the classification of roads adjacent to the subdivision and the size of the project site, road network should result into a hierarchy of functions and should define and serve the subdivisions as one integrated unit.
- b. Roads complemented with pathwalk within the subdivision must be so aligned to facilitate movement within and in linking the subdivision to the nearest major transportation route and adjacent property.

Whenever there is/are existing roads within the project site which shall be made part of the subdivision, these shall be improved in accordance with the standards set forth herein.

- c. Streets should conform to the contours of the land as much as practicable.
- d. Provisions of major street extension for future connection to adjoining developed and/or underdeveloped properties shall be mandatory and integrated or aligned with existing ones, if any.
- e. Streets shall be so laid out to minimize critical intersections such as blind corners, skew junctions, etc.

- f. Roads shall conform with civil work design criteria as per Section 10.B.3 of this Rules and sound engineering practices.

**C. Design Parameters**

**1. Land Allocation**

**a. Saleable Areas**

There shall be no fixed ratio between the saleable portion and non-saleable portion of a subdivision project.

**b. Non-saleable Areas**

Non-saleable areas shall conform with the minimum requirements for open space comprising those allotted for circulation system, community facilities and parks and playgrounds.

**b.1 Allocation of Area for Parks and Playgrounds**

Area allocated for parks and playgrounds shall be mandatory for projects 1 hectare and above and shall be strategically located within the subdivision project.

Allocated areas for parks and playgrounds shall be non-alienable and non-buildable for community hall but buildable for basketball court. It shall be exclusive of those areas allocated for community facilities and shall vary according to the density of lots and/or dwelling units in the subdivision, whichever is applicable, as shown below:

**Table 1. Parks and Playgrounds Allocation**

ECONOMIC HOUSING		SOCIALIZED HOUSING	
Density (No. of lots/DU* per hectare)	Allocation (% of gross area for PP**)	Density (No. of lots/DU* per hectare)	Allocation (% of gross area for PP**)
150 and below	3.5 %	150 and below	3.5 %
151 – 160	4 %	151 – 160	4 %
161 – 175	5 %	161 – 175	5 %
176 – 200	6 %	176 – 200	6 %
201 – 225	7 %	201 – 225	7 %
Above 225	9 %	Above 225	9 %

\* Dwelling units

\*\* Parks and Playgrounds

In no case shall an area allocated for parks and playgrounds be less than 100 square meters. An addition of 1% increment for every 10 or fraction thereof above 225.

The site shall not be subject to flooding nor situated in steep slopes. Sites potentially hazardous or dangerous to the health and safety of users especially children, should be avoided, e.g., along rivers, near dumping site, etc.

*Handwritten mark*

*Handwritten mark*

Location of parks shall be based on hierarchy, accessibility and shall be free from hazards, risks, barriers, etc.

**b.2 Area Allocated for Community Facilities**

Mandatory provision of area for neighborhood multi-purpose center both for economic and socialized housing projects with a gross area of 1 hectare and above. These areas are non-saleable. However, the developer may provide for areas for community facilities such as schools and convenience/retail centers in excess of the requirement set forth in this Rule which shall be deemed saleable. The use of the said area shall be indicated in the plan and annotated in the title thereto. (Refer to Table 2)

**Table 2. Facilities According to the Number of Saleable Lots/Dwelling Units for Subdivision Projects 1 Hectare and Above**

No. of Saleable Lots and/or Dwelling Unit	Neighborhood Multi-Purpose Center*	Convenience/Retail Center**	Elementary School**	High School**	Tricycle Terminal*
10 & below	-	-	-	-	-
11 - 99	-	-	-	-	-
100 - 499	X	-	-	-	-
500 - 999	X	-	-	-	-
1000 - 1499	X	-	-	-	-
1500 - 1999	X	x	x	-	X
2000 - 2499	X	x	x	x	X
2500 - 3000	X	x	x	x	X

\* Mandatory provision of area

\*\* Optional saleable but when provided in the plan the same shall be annotated in the title.

Community facilities shall be strategically located and easily accessible where they can serve a maximum number of population, preferably near or side by side by park/playground.

The area allocated for community facilities shall vary with the density of the subdivision, i.e., number of lots and/or dwelling units whichever is applicable, as shown below:

**Table 3. Community Facilities Allocation**

ECONOMIC HOUSING		SOCIALIZED HOUSING	
Density (No. of lots/DU* per hectare)	Allocation (% of gross area for CF**)	Density (No. of lots/DU* per hectare)	Allocation (% of gross area for CF**)
150 and below	1.0	150 and below	1.0
151 - 225	1.5	151 - 225	1.5
Above 225	2.0	Above 225	2.0

\* Dwelling units

\*\* Community Facilities

*Handwritten signature*

*Handwritten signature*

### b.3 Circulation System

The area allocated for circulation system shall not be fixed, as long as the prescribed dimension and requirements for access (both for project site and dwelling units) specified in these Rules are complied with.

Land circulation system shall comply with the pertinent requirements of BP 344 otherwise known as the Accessibility Law.

Below are the planning considerations to be observed for circulation layout:

- a. Observance of the hierarchy of roads within the subdivision.
- b. Conformance to natural topography.
- c. Consideration for access and safety, e.g., adequate radius, minimum number of roads at intersections, moderate slope/grade, adequate sight distance, no blind corners, etc.
- g. Optimization as to number of lots to lessen area for roads, at the same time enhances community interaction.

#### b.3.1 HIERARCHY OF ROADS

Hierarchy of roads (with respect to function, dimensions and project area) shall be observed when planning the road network such that no major or minor road align with an alley or pathwalk.

**Table 4. Hierarchy of Roads**

PROJECT SIZE RANGE (has)	ECONOMIC HOUSING HOUSING	SOCIALIZED HOUSING
2.5 has. And below	major, minor, motor court, alley	major, minor, motor court, pathwalk,
Above 2.5 – 5	- do -	- do -
Above 5 - 10	major, collector, minor, motor court, alley	- do -
Above 10 - 15	- do -	major, collector, minor, motor court, pathwalk,
Above 15 – 30	- do -	- do -
Above 30	- do -	- do -

### b.3.2 ROAD RIGHT-OF-WAY

The corresponding right-of-way for hierarchy of roads shall be as follows:

**Table 5. Road Right-of-Way**

PROJECT SIZE RANGE (has)	RIGHT OF WAY (m)					
	ECONOMIC HOUSING			SOCIALIZED HOUSING		
	Major	Collector	Minor	Major	Collector	Minor
2.5 and below	8	-	6.5	8	-	6.5
Above 2.5 - 5.0	10	-	6.5	10	-	6.5
Above 5.0 - 10	10	8	6.5	10	-	6.5
Above 10 - 15	10	8	6.5	10	8	6.5
Above 15 - 30	12	8	6.5	10	8	6.5
Above 30	15	10	6.5	12	10	6.5
	ROW		Carriageway	ROW		Carriageway
Motor Court	6		5	6		5
Alley	2		-	-		-
Pathwalk	-		-	3		-

The minimum right-of-way of major roads shall be in accordance with the preceding table. However, in cases where the major road will serve as interconnecting road, it shall have a minimum right-of-way of 10 meters. It shall have a 15-centimeter mix gravel (pit run) basecourse on well compacted subgrade.

Major roads shall maintain a uniform width of road right-of-way. Tapering of road width shall not be allowed where the road right-of-way is wider than the prescribed standard for the interconnecting road of the proposed subdivision.

Minor roads shall have a right-of-way of 6.50 meters wide.

Interior subdivision project must secure right-of-way to the nearest public road and the right-of-way shall be designated as interconnecting road with a minimum width of 10 meters. This fact shall be annotated on the title of the said road lot and must be donated and deemed turned over to the LGU upon completion of the said interconnecting road. (See Figure 1: Interconnecting Road)

Subdivision projects abutting main public road must provide sufficient setbacks with a minimum dimension of 3.0 meters in depth and 5.0 meters in length at both sides of the subdivision entrance to accommodate loading and unloading of passengers. (See Figure 2 : Setback Requirement Along Main Public Road)

Contiguous projects or projects to be developed by phases shall be provided with interconnecting roads with a minimum right-of-way of 10.0 meters. (Approved as per Resolution No. R-374 dated 03 March 1987).

Alley shall have a width of 2.0 meters intended to break a block and to serve both pedestrian and for emergency purposes, both ends connecting to streets. It shall not be used as access to the property.

Pathwalk shall have a width of 3.0 meters intended only to provide pedestrian access to property for socialized housing projects. It shall have a maximum length of 60 meters.

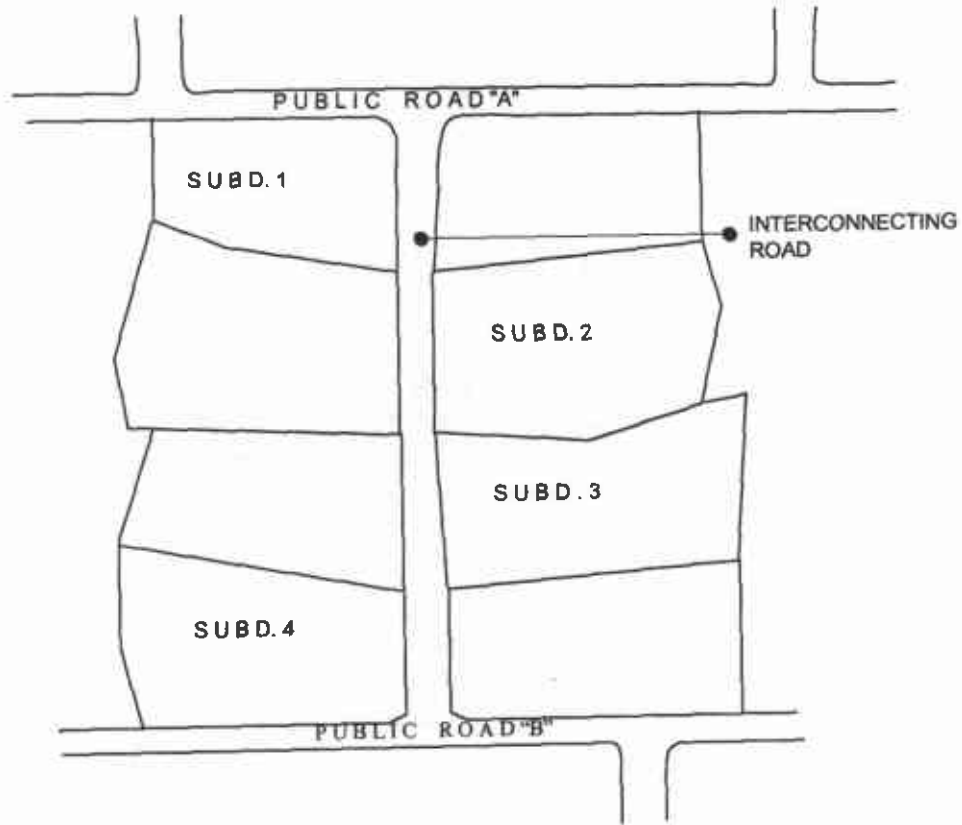

Figure 1. Interconnecting Road

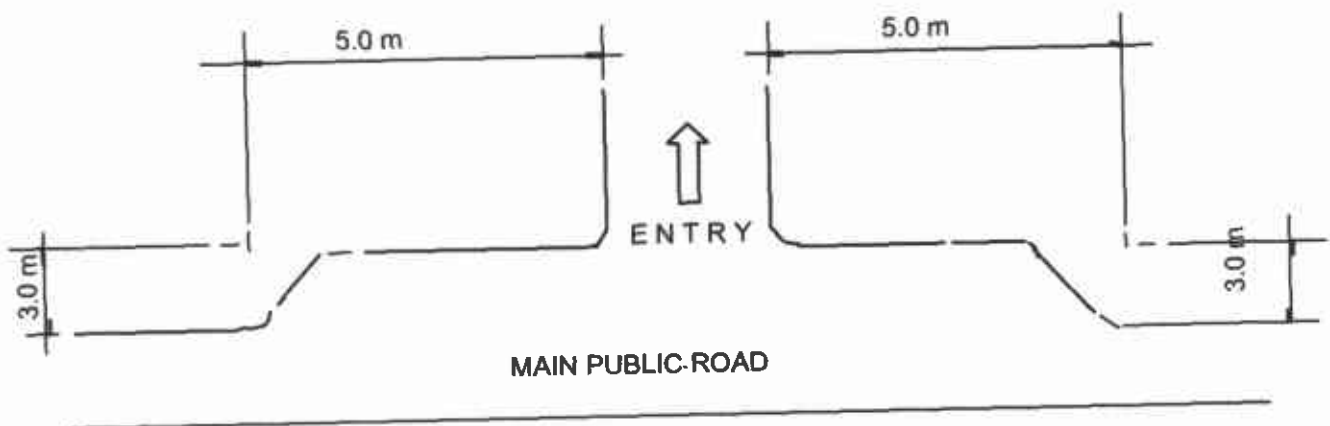

Figure 2. Setback Requirement Along Main Public Road

### b.3.3 PLANTING STRIPS

Planting strips shall be observed in accordance with the following table:

**Table 6. Width of Planting Strips and Sidewalks**

RIGHT-OF-WAY (m)	ECONOMIC HOUSING		SOCIALIZED HOUSING	
	Planting Strip (m)	Sidewalk (m)	Planting Strip (m)	Sidewalk (m)
15	1.3	1.2	1.3	1.2
12	0.8	1.2	0.8	1.2
10	0.8	1.2	0.8	1.2
8	0.4	0.6	0.4	0.6
6.5	Optional	0.5	Optional	0.5

### b.3.4 Road Pavement

Major, minor roads and motorcourt for economic and socialized housing projects shall be paved with asphalt with minimum thickness of 50 millimeters or concrete with minimum thickness of 150 millimeters and a minimum compressive strength of 20.7 Mpa at 28 days. Sidewalk or alley shall be of macadam finish.

### b.3.5 Road Intersection

Roads should intersect at right angles as much as practicable. Multiple intersections along major roads shall be minimized. Distance between offset intersections should not be less than 20 meters from corner to corner.

Road intersections shall be provided with adequate curb radii consistent with sound engineering principles. (See Figure 3 : Curb Radii Dimension)

### b.3.6 Road Grade/Slope

Crown of the roads shall have a slope of not less than 1.5 to 9 percent. (See Figure 4 : Road Grade Slope)

Grades and vertical curbs shall conform to the design requirements of the Department of Public Works and Highways (DPWH).

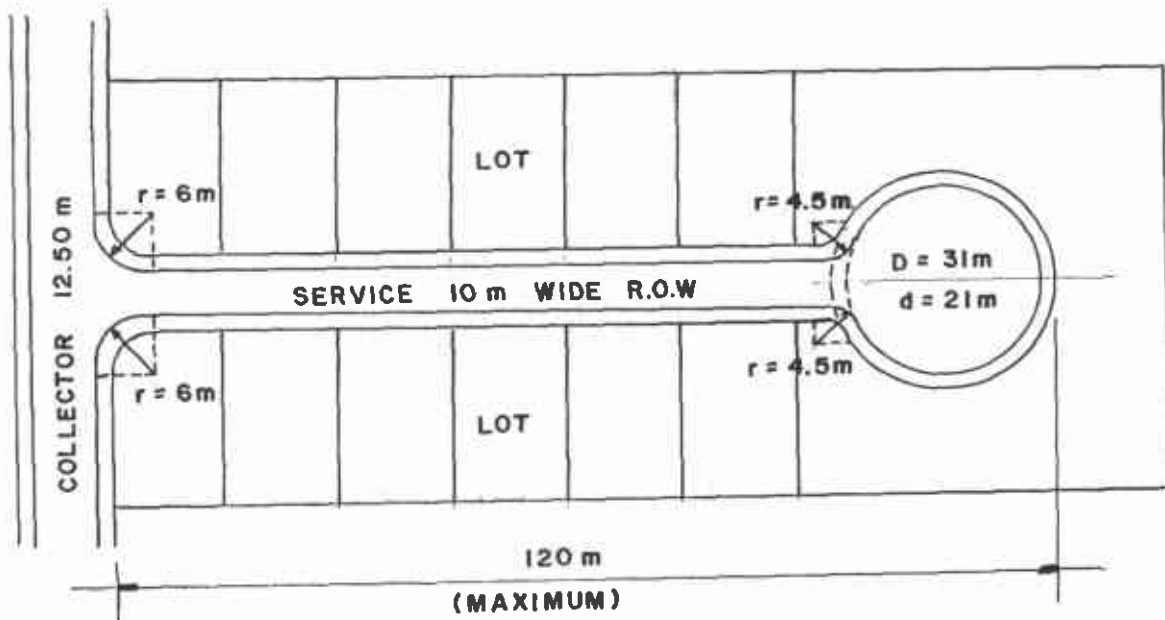

**CUL - DE - SAC**

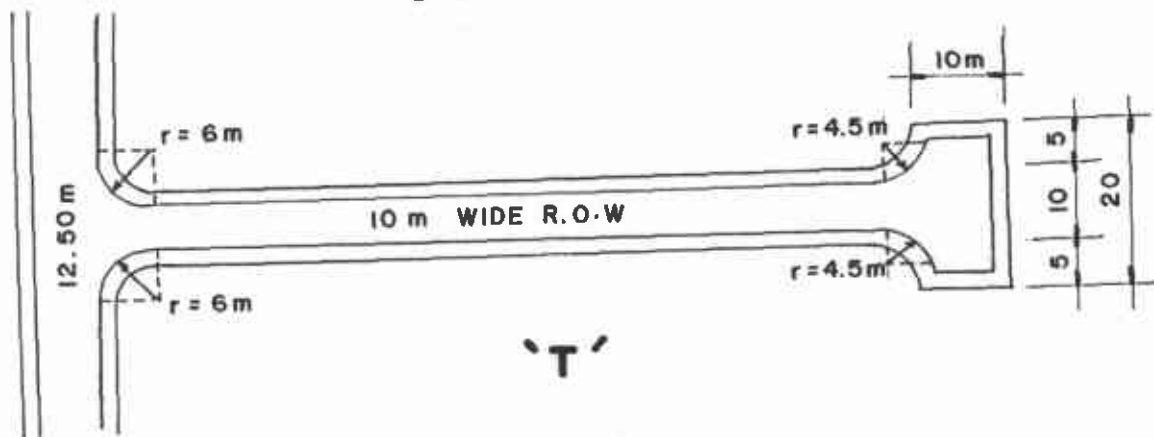

**T**

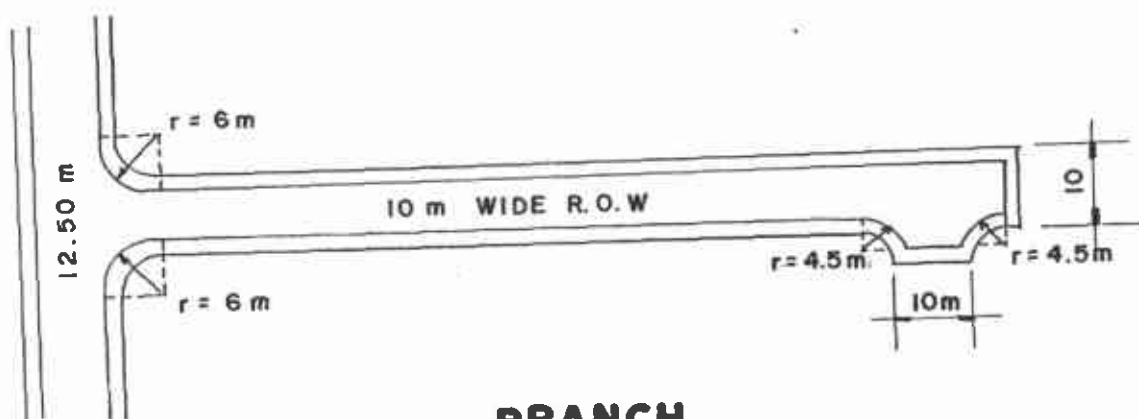

**BRANCH**

$r$  = CURB RADIUS

NOT TO SCALE

Figure 3. Curb Radii Dimension

*Handwritten mark*

*Handwritten signature*

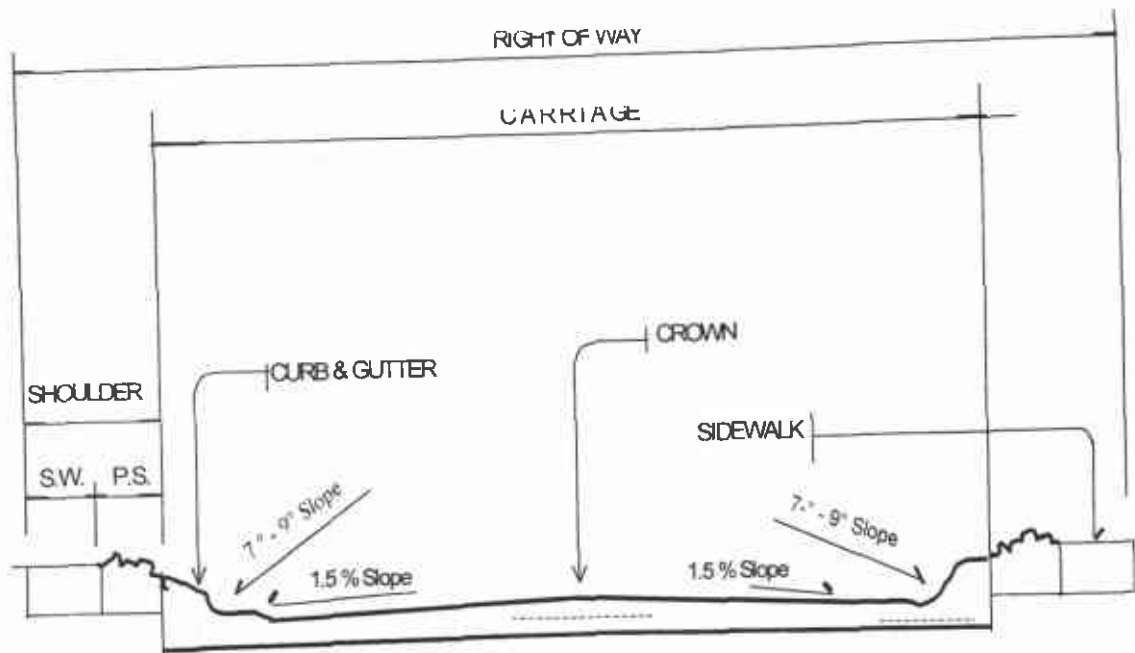

Figure 4. Road Grade (Slope)

## 2. Lot Requirement

### a. Lot Planning

- a.1 A lot shall be served by an independent access either by a road, motor court, or pathwalk. Pathwalk shall have a maximum length of 60 meters intended only as pedestrian access to property for socialized housing projects.
- a.2 Deep lots and irregularly shaped lots shall be avoided.
- a.3 Whenever possible, lot frontage elevation shall be at street level.
- a.4 Lots shall be protected against physical hazards. No lot shall be laid out where potential risks exist (e.g. erosion, slides, flooding, faultlines, etc.)
- a.5 Lots shall be protected against non-conforming uses and/or other risks through the provision of adequate buffer strips, protective walls, and roads or other similar devices.
- a.6 Lot shall be so laid out that administrative boundaries, water courses/drainage ways utility lines do not bisect the lots.

*Handwritten mark*

*Handwritten signature*

### b. Minimum Lot Area

The minimum lot area of various types of housing for economic and socialized housing project shall be as follows:

**Table 7. Minimum Lot Area**

TYPES OF HOUSING	ECONOMIC (sqm)	SOCIALIZED (sqm)
a. Single Detached	72	64
b. Duplex/Single Attached	54	48
c. Rowhouses	36	32

**NOTE:**

1. Saleable lots designated as duplex/single attached and/or rowhouse lots shall be provided with housing components.
2. Price of saleable lots intended for single detached units shall not exceed 40% of the maximum selling price of the house and lot package.

### c. Lot Frontages

The minimum lot frontages for various types of housing both for economic and socialized housing projects shall be as follows:

**Table 8. Minimum Lot Frontage**

TYPES OF HOUSING / LOT	FRONTAGE (m)
1. Single Detached	
a. Corner Lot	8
b. Regular Lot	8
c. Irregular Lot	4
d. Interior Lot	3
2. Duplex/Single Attached	6
3. Rowhouse	4

**NOTE:**

For rowhouses, there shall be a maximum of 20 units per block or cluster but in no case shall this be more than 100 meters in length.

### 3. Length of Block

Maximum block length is 400 meters. However, block length exceeding 250 meters shall already be provided with a 2-meter alley approximately at midlength.

*Handwritten initials*

*Handwritten signature*

#### 4. Shelter Component

##### a. Floor Area Requirement

The minimum floor area requirement for single-family dwelling shall be 22 square meters for economic housing and 18 square meters for socialized housing.

##### b. Minimum Level of Completion

The minimum level of completion for economic housing shall be complete house based on the submitted specifications. For socialized housing project, it shall be shell house with doors and windows to enclose the unit.

Provision of firewall shall be mandatory for duplex and single attached units and at every unit for rowhouses.

#### 5. Setback/Yard

The minimum setback of dwelling unit both for economic and socialized housing project shall be as follows:

- |                  |  |
|------------------|--|
| a. Front Setback | 1.5 m.   |
| b. Side yard     | 1.5 m (from the building line)   |
| c. Rear yard     | 2.0 m.   |
| d. Abutments     | May be allowed per requirements of the National Building Code of the Philippines |

#### 6. Water Supply

Whenever a public water supply system exists, connection to it by the subdivision is mandatory.

Each lot and/or living unit shall be served with water connection (regardless of the type of distribution system). Water supply provided by the local water district shall be potable and adequate. It shall be complemented/supplemented by other sources, when necessary, such as communal well which may be located strategically for ease and convenience in fetching water by residents and at the same time not closer than 300 meters from each other.

If public water supply system is not available, the developer shall provide for an independent water supply system within the subdivision project. Minimum quantity requirement shall be 150 liters per capita per day.

Each subdivision must have at least an operational deepwell and pump sets with sufficient capacity to provide average daily demand (ADD) to all homeowners provided a spare pump and motor set is reserved.

Likewise, required permits from the NWRB shall be obtained and standards of the Local Water Utilities Administration (LWUA) shall be complied with.

If ground reservoir is to be put up, an area shall be allocated for this purpose (part of allocation for community facilities). The size shall depend on volume of water intended to be stored. It shall be protected from pollution by providing buffer of at least 25 meters from sources of pollution/contamination.

For elevated reservoir, structural design shall comply with accepted structural standards or the National Building Code of the Philippines. The elevated reservoir or water tank capacity must be 20% average daily demand plus fire reserve.

Alternative sources of water supply may be availed of such as collected rain water and other devices with water impounding capacity.

Provision for fire protection shall comply with the requirements of the Fire Code of the Philippines. Whichever is applicable, the Local Government Unit shall provide each community with fire hydrants and a cistern that are operational at all times.

For multi-storey building, a water tank shall be provided if the height of the building requires pressure in excess of that in the main water line. Capacity should be 20% average daily demand plus fire reserve.

## **7. Electrical Power Supply**

When power is available within the locality of the project site, its connection to the subdivision is required. Actual connection, however, may depend on the minimum number of users as required by the power supplier.

Provision of street lighting per pole shall be mandatory if poles are 50-meter distance and at every other pole if the distance is less than 50 meters.

Installation practices, materials and fixtures used, shall be in accordance with the provisions of the existing rules and regulations of the National Electrical Code of the Philippines or the Local Electric Franchise Holder/Local Electric Cooperative or the local utility company.

Electric bills shall be proportionately shouldered by the users prior to issuance of Certificate of Completion (COC) and turn over of open space to Local Government Unit (LGU).

## **8. Sewage Disposal System**

### **a. Septic Tank**

The sewage disposal system shall be communal or individual septic tank conforming to the design standard of the Sanitation Code of the Philippines.

### **b. Connection to Community Sewer System**

Whenever applicable, connections shall be made to an approved public or community sewer system, subject to the requirements and provisions of

the Sanitation Code of the Philippines and other applicable rules and regulations with regard to materials and installation practices.

## **9. Drainage System**

The design of the drainage system of the subdivision shall take into consideration existing development of adjacent areas relative to their impact/effect on its drainage system, if any. Further, it shall conform with the natural drainage pattern of the subdivision site, and shall drain into appropriate water bodies or public drainage system or natural outfalls. In no case shall drainage outfalls drain into a private lot. Its layout shall conform with sound engineering design principles certified by a duly licensed civil/sanitary engineer. Drain lines shall be of durable materials and approved installation practices.

The minimum drainage system for economic and socialized housing shall be concrete lined canal with load bearing cover.

In case of non-existence of drainage system in the locality, catchment area for drainage discharge shall be provided for and developed by the owner/developer in consultation with local authorities or private entities concerned, to prevent flooding of adjacent property. Moreover, said catchment area shall be made safe and maintained.

If applicable, underground drainage system shall be provided with adequate reinforced concrete pipes (RCP), catch basins, manholes/inlets and cross drain for efficient maintenance. Minimum drainage pipe shall be 300 millimeters.

## **10. Garbage Disposal System**

Garbage disposal shall be undertaken by the local government or in the absence thereof, by individual lot owners or homeowners association, with proper observance of sanitary practices and methods.

## **11. Fire Firefighting**

The Homeowners Association shall form fire brigade in collaboration with the barangay fire brigade. Water for fire fighting shall be part of the water supply requirements and shall comply with the requirements of the local/district fire unit of the Philippine National Police.

*Handwritten mark*

*Handwritten mark*

**Table 9. PLANNING AND DESIGN STANDARDS  
FOR A RESIDENTIAL SUBDIVISION PROJECT  
UNDER BP 220**

PARAMETERS	ECONOMIC HOUSING		SOCIALIZED HOUSING	
1. Project Location	Within suitable sites for housing and outside potential hazard prone and protection areas.			
2. Land Allocation for Projects 1 hectare and above	<p>a. Variable</p> <p>b. See open space requirement as per b.1, b.2 and b.3</p> <p>Mandatory allocation for parks and playgrounds per tabulation below:</p>			
b.1 Area for parks and playgrounds for projects 1 hectare & above.	<p>Density (No. of Lots or Dwelling Unit Per Hectare)</p> <p>150 &amp; below</p> <p>151 – 160</p> <p>161 – 175</p> <p>176 – 200</p> <p>201 – 225</p> <p>Above 225</p>	<p>% of Gross Area for Parks &amp; Playgrounds</p> <p>3.5%</p> <p>4.0%</p> <p>5.0%</p> <p>6.0%</p> <p>7.0%</p> <p>9.0%</p>	<p>Density (No. of Lots or Dwelling Unit Per Hectare)</p> <p>150 &amp; below</p> <p>151 – 160</p> <p>161 – 175</p> <p>176 – 200</p> <p>201 – 225</p> <p>Above 225</p>	<p>% of Gross Area for Parks &amp; Playgrounds</p> <p>3.5%</p> <p>4.0%</p> <p>5.0%</p> <p>6.0%</p> <p>7.0%</p> <p>9.0%</p>
	An addition of 1% increment for every 10 or fraction thereof above 225.			
	In no case shall an area allocated for parks and playgrounds be less than 100 square meters. The same shall be strategically located within the subdivision project.			
b.2 Area for community facilities	Mandatory provision of area for neighborhood multi-purpose center both for economic and socialized housing projects with area of 1 hectare and above. These areas are non-saleable. However, the developer may provide for areas for community facilities such as schools and convenience/retail centers in excess of the mandatory requirement set forth in this rule which shall be deemed saleable. The use of the said area shall be indicated in the plan and annotated in the title thereto. (Refer to Table 2)			
	<p>Density (No. of lots or Dwelling Units Per Hectare)</p> <p>150 &amp; below</p> <p>151 – 225</p> <p>Above 225</p>	<p>% of Gross Area for Community Facilities</p> <p>1.0%</p> <p>1.5%</p> <p>2.0%</p>	<p>Density (No. of lots or Dwelling Units Per Hectare)</p> <p>150 &amp; below</p> <p>151 – 225</p> <p>Above 225</p>	<p>% of Gross Area for Community Facilities</p> <p>1.0%</p> <p>1.5%</p> <p>2.0%</p>
b.3 Circulation System	Observe hierarchy of roads			

*Handwritten mark*

*Handwritten mark*

PARAMETERS	ECONOMIC HOUSING			SOCIALIZED HOUSING																																																																				
<b>3. Minimum Lot Areas</b> a. Single Detached b. Duplex/Single-Attached c. Rowhouse	72 sqm. 54 sqm. 36 sqm.	64 sqm. 48 sqm. 32 sqm.		<p>Saleable lots designated as duplex/single-attached and/or rowhouse lots shall be provided with housing components.</p> <p>Price of saleable lots intended for single-detached units shall not exceed 40% of the maximum selling price for house and lot package.</p>																																																																				
<b>4. Minimum Lot Frontage</b> 4.1 Single Detached a. corner lot b. regular lot c. irregular lot d. interior lot 4.2 Single Attached/ Duplex 4.3 Rowhouse	8 m. 8 m. 4 m. 3 m. 6 m. 4 m.																																																																							
<b>5. Length of Block</b>	<p>Maximum length of block is 400 meters. However, blocks exceeding 250 meters shall be provided with a 2-meter alley approximately at midlength.</p>																																																																							
<b>7. Road Right-of-Way</b>  Project Size Range  2.5 has. & below Above 2.5 – 5 has. Above 5 – 10 has. Above 10 – 15 has. Above 15 – 30 has. Above 30 has.  Motor Court Alley Pathwalk	<table border="0"> <tr> <td>Major (m)</td> <td>Collector (m)</td> <td>Minor (m)</td> </tr> <tr> <td>8</td> <td>-</td> <td>6.5</td> </tr> <tr> <td>10</td> <td>-</td> <td>6.5</td> </tr> <tr> <td>10</td> <td>8</td> <td>6.5</td> </tr> <tr> <td>10</td> <td>8</td> <td>6.5</td> </tr> <tr> <td>12</td> <td>8</td> <td>6.5</td> </tr> <tr> <td>15</td> <td>10</td> <td>6.5</td> </tr> <tr> <td>ROW</td> <td>Carriageway</td> <td></td> </tr> <tr> <td>6</td> <td>5</td> <td></td> </tr> <tr> <td>2</td> <td>-</td> <td></td> </tr> <tr> <td>-</td> <td>-</td> <td></td> </tr> </table>	Major (m)	Collector (m)	Minor (m)	8	-	6.5	10	-	6.5	10	8	6.5	10	8	6.5	12	8	6.5	15	10	6.5	ROW	Carriageway		6	5		2	-		-	-		<table border="0"> <tr> <td>Major (m)</td> <td>Collector (m)</td> <td>Minor (m)</td> </tr> <tr> <td>8</td> <td>-</td> <td>6.5</td> </tr> <tr> <td>10</td> <td>-</td> <td>6.5</td> </tr> <tr> <td>10</td> <td>-</td> <td>6.5</td> </tr> <tr> <td>10</td> <td>8</td> <td>6.5</td> </tr> <tr> <td>10</td> <td>8</td> <td>6.5</td> </tr> <tr> <td>12</td> <td>8</td> <td>6.5</td> </tr> <tr> <td>12</td> <td>10</td> <td>6.5</td> </tr> <tr> <td>ROW</td> <td>Carriageway</td> <td></td> </tr> <tr> <td>6</td> <td>5</td> <td></td> </tr> <tr> <td>2</td> <td>-</td> <td></td> </tr> <tr> <td>3</td> <td>-</td> <td></td> </tr> </table>		Major (m)	Collector (m)	Minor (m)	8	-	6.5	10	-	6.5	10	-	6.5	10	8	6.5	10	8	6.5	12	8	6.5	12	10	6.5	ROW	Carriageway		6	5		2	-		3	-	
Major (m)	Collector (m)	Minor (m)																																																																						
8	-	6.5																																																																						
10	-	6.5																																																																						
10	8	6.5																																																																						
10	8	6.5																																																																						
12	8	6.5																																																																						
15	10	6.5																																																																						
ROW	Carriageway																																																																							
6	5																																																																							
2	-																																																																							
-	-																																																																							
Major (m)	Collector (m)	Minor (m)																																																																						
8	-	6.5																																																																						
10	-	6.5																																																																						
10	-	6.5																																																																						
10	8	6.5																																																																						
10	8	6.5																																																																						
12	8	6.5																																																																						
12	10	6.5																																																																						
ROW	Carriageway																																																																							
6	5																																																																							
2	-																																																																							
3	-																																																																							
<p>The minimum right-of-way of major roads shall be in accordance with the preceding table. However, in cases where the major road will serve as interconnecting road, it shall have a minimum right-of-way of 10 meters. It shall have a 15-centimeter mix gravel (pit run) basecourse on well compacted subgrade.</p> <p>Major roads shall maintain a uniform width of road right-of-way. Tapering of road width shall not be allowed where the road right-of-way is wider than the prescribed standard for the interconnecting road of the proposed subdivision.</p> <p>Minor road shall have a minimum right-of-way of 6.50 meters.</p>																																																																								

*Handwritten mark*

*Handwritten mark*

PARAMETERS	ECONOMIC HOUSING	SOCIALIZED HOUSING																		
<p>6. Road Right-of-Way (cont'd)</p>	<p>NOTE:</p> <ol style="list-style-type: none"> <li>Interior subdivision project must secure right-of-way to the nearest public road and the right-of-way shall be designated as interconnecting road with a minimum right-of-way of 10 meters. This fact shall be annotated on the title of said road lot and must be donated and deemed turned over to the LGU upon completion of the said interconnecting road. (See figure 1)</li> <li>Subdivision projects abutting main public thoroughfare must provide sufficient setbacks (at least 3.0 meters in depth by 5.0 meters in length) at both sides of the subdivision entrance to accommodate loading and unloading of passengers. (See figure 2)</li> <li>Contiguous projects or projects to be developed by phases shall be provided with interconnecting road with a minimum right-of-way of 10 meters.</li> <li>Alley shall have a width of 2.0 meters intended to break a block and to serve both pedestrian and for emergency purposes, both ends connecting to streets. It shall not be used as access to property.</li> <li>Pathwalk shall have a width of 3.0 meters intended only to provide pedestrian access to property for socialized housing projects. It shall have a maximum length of 60 meters.</li> </ol>																			
<p>8. Hierarchy of Roads per Project Size Range</p> <p>2.5 has. &amp; below</p> <p>Above 2.5 – 5 has.</p> <p>Above 5 – 10 has.</p> <p>Above 10 – 15 has.</p> <p>Above 15 – 30 has.</p> <p>Above 30 has.</p>	<p>Major, minor, motor court, alley</p> <p>-do-</p> <p>Major, collector, minor, motor court, alley</p> <p>-do-</p> <p>-do-</p> <p>-do-</p> <p>-do-</p>	<p>Major, minor, motor court, pathwalk</p> <p>-do-</p> <p>-do-</p> <p>Major, collector, minor, motor court, pathwalk</p> <p>-do-</p> <p>-do-</p>																		
<p>9. Roads Specifications</p> <p>9.1 Planting Strip (PS) Sidewalk (SW)</p> <p>ROW</p> <p>15.0 m.</p> <p>12.0 m.</p> <p>10.0 m.</p> <p>8.0 m.</p> <p>6.5 m.</p>	<table border="1"> <thead> <tr> <th></th> <th>PS</th> <th>SW</th> </tr> </thead> <tbody> <tr> <td>15.0 m.</td> <td>1.30 m</td> <td>1.20 m</td> </tr> <tr> <td>12.0 m.</td> <td>0.80 m</td> <td>1.20 m</td> </tr> <tr> <td>10.0 m.</td> <td>0.80 m</td> <td>1.20 m</td> </tr> <tr> <td>8.0 m.</td> <td>0.40 m</td> <td>0.60 m</td> </tr> <tr> <td>6.5 m.</td> <td>optional</td> <td>0.50 m</td> </tr> </tbody> </table>			PS	SW	15.0 m.	1.30 m	1.20 m	12.0 m.	0.80 m	1.20 m	10.0 m.	0.80 m	1.20 m	8.0 m.	0.40 m	0.60 m	6.5 m.	optional	0.50 m
	PS	SW																		
15.0 m.	1.30 m	1.20 m																		
12.0 m.	0.80 m	1.20 m																		
10.0 m.	0.80 m	1.20 m																		
8.0 m.	0.40 m	0.60 m																		
6.5 m.	optional	0.50 m																		

ok  
Dinner

Jan

PARAMETERS	ECONOMIC HOUSING	SOCIALIZED HOUSING
<p>9.2 Road Pavement</p> <p>Major Minor Motor Court Sidewalk Pathwalk/Alley</p>	<p>Concrete/Asphalt Concrete/Asphalt Macadam Macadam Macadam</p> <p>Concrete road pavement shall have a minimum thickness of 150 millimeters and a minimum compressive strength of 20.7 MPa at 28 days. Asphalt pavement shall have a minimum thickness of 50 millimeters.</p>	
<p>10. Water Supply</p> <p>10.1 Minimum Water Supply Requirement</p> <p>10.2 Fire Protection Demand</p>	<p>Mandatory connection to appropriate public water system. Each subdivision shall have at least an operational deepwell and pump sets with sufficient capacity to provide ADD to all homeowners provided further that a spare pump and motor set is reserved. Water supply shall be potable and adequate.</p> <p>150 liters per capita per day for household connection</p> <p>Provision for fire protection facilities shall comply with the requirements of the Fire Code of the Philippines.</p>	
<p>10. Electrical Power Supply</p>	<p>Mandatory individual household connection to primary and alternate sources of power if service is available in the locality.</p> <p>Mandatory provision of street lighting per pole if 50-meter distance; at every other pole, if the distance is less than 50 meters.</p> <p>Electric bills shall be proportionately shouldered by users prior to issuance of COC and turn over of open space to LGU.</p> <p>Installation practices, materials and fixtures used shall be in accordance with the provision of the Philippine Electrical Code and local utility company.</p>	
<p>12. Drainage System</p>	<p>The drainage system for economic and socialized housing projects shall be made of concrete lined canal with adequate capacity and with load bearing cover.</p> <p>The drainage system must conform with the natural drainage pattern of the subdivision site, and shall drain into appropriate water bodies, public drainage system or natural outfalls.</p> <p>If applicable, underground drainage system shall be provided with adequate reinforced concrete pipes (RCP), catch basins, manholes/inlets and cross drain for efficient maintenance. Minimum drainage pipe diameter shall be 300 millimeters.</p>	

PARAMETERS	ECONOMIC HOUSING	SOCIALIZED HOUSING
<b>13. Sewage Disposal System</b>		
13.1 Septic Tank	Individual septic tank conforming to the standards and design of Sanitation Code of the Philippines.  Construction of individual septic tanks shall conform to the standards and design of Sanitation Code of the Philippines.	
13.2 Connection to Community Sewer System	Whenever applicable, connection shall be made to an approved public or community sewer system subject to the requirements and provisions of the Sanitation Code of the Philippines and other applicable rules and regulations.	
<b>14. Garbage Disposal System</b>	Provide sanitary and efficient refuse collection and disposal system whether independently or in conjunction with the local government garbage collection and disposal services.	
<b>15. Shelter Component</b>		
15.1 Minimum Floor Area		
a. Single Detached	22 sqm.	18 sqm.
b. Duplex/Single Attached	22 sqm.	18 sqm.
c. Rowhouse	22sqm.	18 sqm.
	Mandatory provision of firewall for duplexes/single-attached units and at every unit for rowhouses (See Figure 11)  The number of rowhouses shall not exceed 20 units per block/cluster but in no case shall this be more than 100 meters in length.	
15.2 Minimum Level of Completion		
a. Single Detached	Complete house (Based on the submitted specifications) same	Shell house (with doors and windows to enclose the unit) same
b. Duplex/Single Attached	same	same
c. Rowhouses	same	same
<b>16. Setback/Yard</b>		
a. Front setback		1.5 m
b. Side yard		1.5 m (from the building line)
c. Rear yard		2.0 m
d. Abutments	May be allowed per requirement of the National Building Code of the Philippines	

## Section 6. Building Design Standards and Guidelines

Projects incorporating housing components shall comply with the following design standards and guidelines.

### A. Single Family Dwelling (Applicable for both Economic and Socialized Housing)

#### 1. Lot Planning

##### a. Access to the Property

Direct access to the single-family dwelling shall be provided by means of an abutting public street or pathwalk. However, pathwalk shall only be allowed as pedestrian access to property for Socialized Housing projects.

##### b. Access to the Dwelling Unit

An independent means of access to the dwelling unit shall be provided without trespassing adjoining properties. Acceptable means of access to the rear yard of the dwelling unit shall be provided without passing through any other dwelling unit or any other yard.

##### c. Open Space Requirements

Open spaces shall be located totally or distributed anywhere within the lot in such a manner as to provide maximum light and ventilation into the building.

##### d. Sizes and Dimensions of Courts or Yards

The minimum horizontal dimension of courts and yards shall not be less than 2.0 meters. All inner courts shall be connected to a street or yard, either by a passageway with a minimum width of 1.20 meters or by a door through a room or rooms.

Every court shall have a width of not less than 2.0 meters for one and two storey buildings. However, this may be reduced to not less than 1.50 meters in cluster living units such as quadruplexes, rowhouses and the like one or two stories in height with adjacent courts with an area of not less than 3 square meters. Provided, further, that the separation walls or fences, if any, shall be not higher than 2.0 meters. Irregularly shaped lots such as triangular lots and the like whose courts may be also triangular in shape may be exempted from having a minimum width of 2.0 meters, provided that no side thereof shall be less than 3.0 meters.

##### e. Abutments

Abutments on the side and rear property lines may be allowed provided the following requirements shall be complied with:

1. Open space as prescribed in the table below:

**Table 10. Private Open Space Requirements**

Type of Lot	Percent of Open Space	
	Residential	All Others
a. Interior lot (lot located in the interior of a block made accessible from a public street or alley by means of a private access road)	50%	25%
b. Inside lot (non-corner or single frontage lot)	20%	15%
c. Corner and/or through lot	10%	15%
d. Lots bounded on 3 or more sides by public open spaces such as streets, easement of seashores, rivers, esteros, etc.	5%	5%

2. Window opening as prescribed in Section 6.A.2.c below.

3. Firewall shall have a minimum of one-hour fire resistive rating.

**2. Building Design Standards (Applicable for both Economic and Socialized Housing)**

**a. Space Standards**

Spaces within the dwelling structures shall be distributed in an economical, efficient and practical manner so as to afford the maximum living comfort and convenience and to insure health and safety among the occupants. It shall provide complete living facilities for one family including provisions for living, sleeping, laundry, cooking, eating, bathing and toilet facilities.

**b. Ceiling Heights**

1. Minimum ceiling height for habitable rooms shall be measured from the finished floor line to the ceiling line. Where ceilings are not provided, a minimum headroom clearance of 2.0 meters shall be provided. (See Figure 5 : Minimum Ceiling Heights)
2. Mezzanine floors shall have a clear ceiling height of not less than 1.80 meters above and below it, provided that it shall not cover 50% of the floor area below it. (See Figure 6 : Mezzanine Floor)

**c. Openings**

**1. Doors**

- a. A minimum of one entrance/exit shall be provided where the number of occupants is not more than 10 and 2 entrances/exits where the number of occupants is greater than 10.
- b. Doors shall have a minimum clear height of 2.0 meters. Except for bathroom and mezzanine doors which shall have a minimum clear height of 1.80 meters.

c. Minimum clear widths of doors shall be as follows:

Main Door	0.80 m.
Service/Bedroom Doors	0.70 m.
Bathroom Door	0.60 m.

(See Figure 7 : Door Openings)

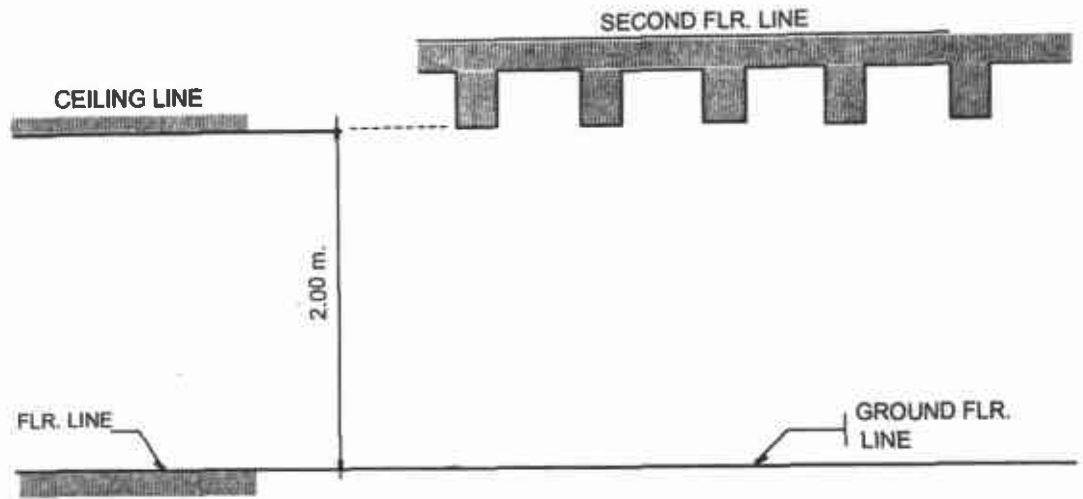

Figure 5. Minimum Ceiling Heights

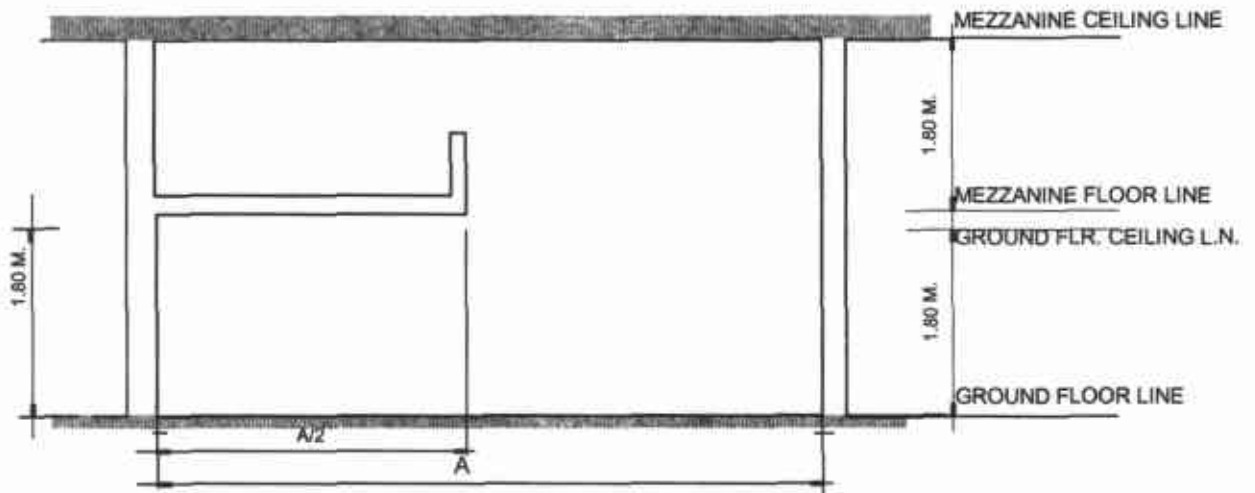
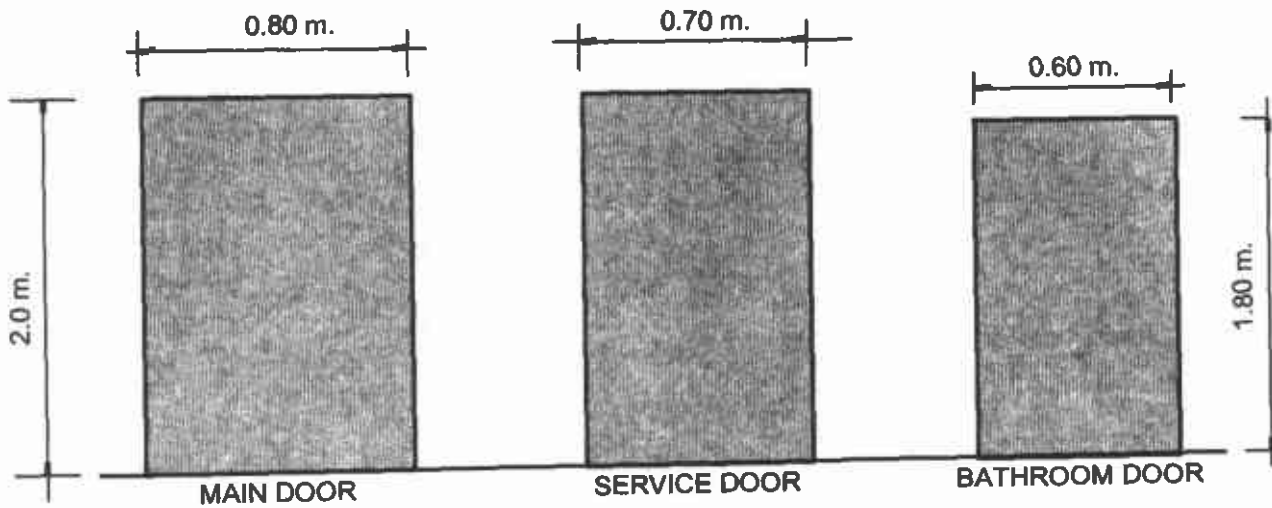

Figure 6. Mezzanine Floor



**Figure 7. Door Openings**

## 2. Windows

- a. Rooms for habitable use shall be provided with windows with a total free area of openings equal to at least 10% of the floor area of the room.
- b. Bathrooms shall be provided with window/s with an area not less than 1/20 of its floor area.
- c. Required windows may open into a roofed porch where the porch:
  1. abuts court, yard, public street or alley, or open water course and other public open spaces;
  2. has a ceiling height of not less than 2.0 meters.

## 3. Interior Stairs

The stairs shall ensure structural safety for ascent and descent, even in extreme cases of emergency. It shall afford adequate headroom and space for the passage of furniture.

1. Width. Stairways shall have a minimum clear width of 0.60 meter.
2. Riser and Run. Stairs shall have a maximum riser height of 0.25 meter and a minimum tread width of 0.20 meter. Stair treads shall be exclusive of nosing and/or other projections.
3. Headroom Clearance. Stairs shall have a minimum headroom clearance of 2.0 meters. Such clearance shall be established

by measuring vertically from a place parallel and tangent to the stairway tread moving to the soffit above all points.

4. Landings. Every landing shall have a dimension measured in the direction of travel equal to the width of the stairway. Maximum height between landing shall be 3.60 meters.
5. Handrails. Stairways shall have at least one handrail on one side provided there is a guard or wall on the other side. However, stairways with less than 4 risers need not have handrails, and stairs with either a guard or wall on one end need not be provided with a handrail on that end.
6. Guard and Handrail Details. The design of guards and handrails and hardware for attaching handrails to guards, balusters of masonry walls shall be such that these are made safe and convenient.
  - a. Handrails on stairs shall not be less than 0.80 meter or more than 1.20 meters above the upper surface of the tread, measured vertically to the top of the rail from the leading edge of the tread. (See Figure 8 : Stairway Design)
  - b. Handrails shall be so designed as to permit continuous sliding of hands on them and shall be provided with a minimum clearance of 38 millimeters. From the wall to which they are fastened. (See Figure 8 : Stairway Design).
  - c. The height of guards shall be measured vertically to the top guard from the leading edge of the tread or from the floor of landings. It shall not be less than 0.80 meter and no more than 1.20 meters. Masonry walls may be used for any portion of the guard.
7. Winding and Circular Stairways. Winding and circular stairways may be used if the required width of run is provided at a point not more than 300 millimeters from the side of the stairway where the treads are narrower but in no case shall any width of run be less than 150 millimeters at any point. The maximum variation in the height of risers and the width of treads in any one flight shall be 5 millimeters. (See Figure 9 : Winding and Circular Stairways)
8. Ladders. The use of ladders may be allowed provided that the maximum distance between landings shall be 1.80 meters.

#### d. Roofing

Roofing material that is impervious to water shall be provided.

any  
now

John

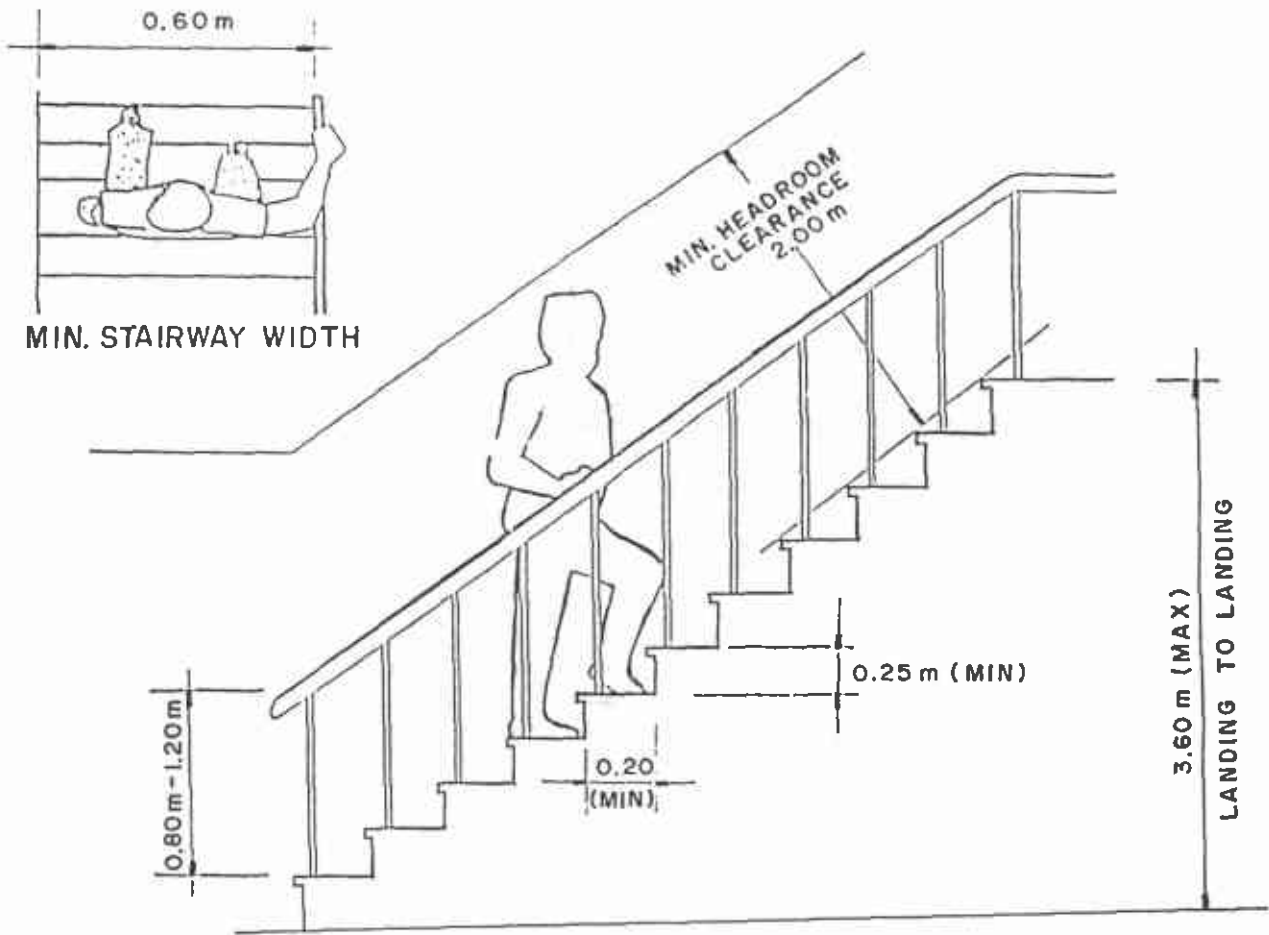

Figure 8. Stairway Design

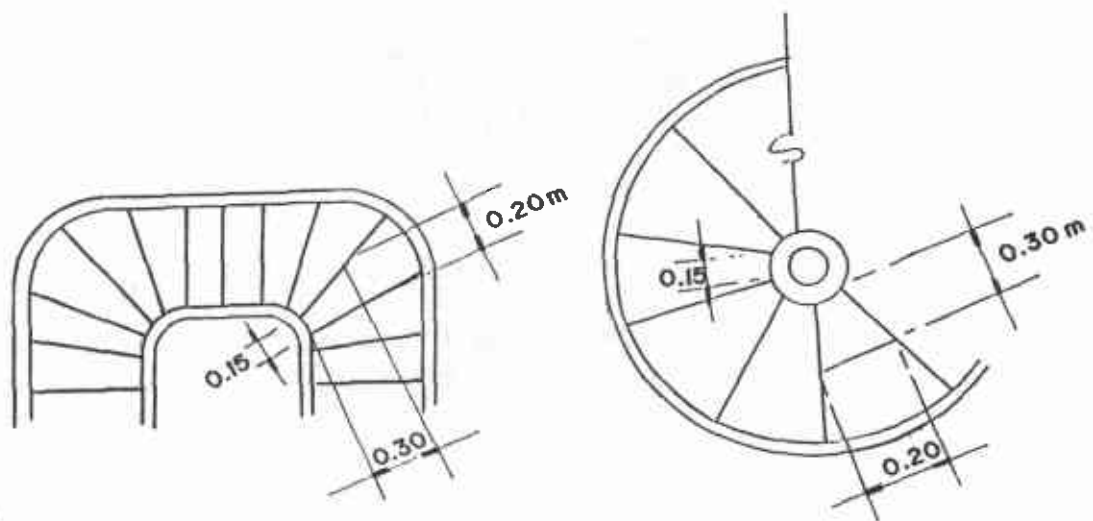

Figure 9. Winding and Circular Stairways

### e. Electrical Requirements

There shall be provided at least one light outlet and one convenience outlet per activity area.

### f. Fireblocks

When any 2 living units abut each other, a fireblock shall be required in which case the fireblock shall be the masonry construction (e.g. cement, hollow blocks, bricks, reinforced concrete, etc.), at least 100 millimeters and shall extend from the lowest portion of the wall adjoining the 2 living units up to the point just below the roof covering or purlins. (See Figure 10 : Fireblocks for Dwelling Units That Abut Each Other)

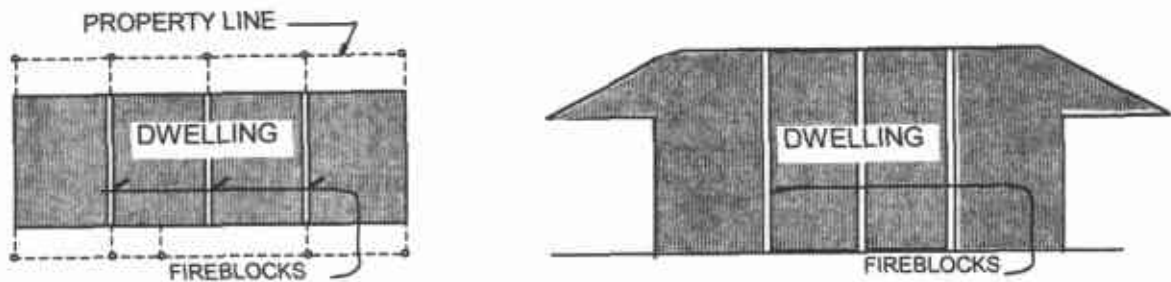

**Figure 10. Fireblocks for Dwelling Units That Abut Each Other**

### h. Firewall

Whenever a dwelling abuts on a property line, a firewall shall be required. The firewall shall be of masonry construction, at least 100 millimeters thick, and extend vertically from the lowest portion of the wall adjoining the living units up to a minimum height of 0.30 meter above the highest point of the roof attached to it the firewall shall also extend horizontally up to a minimum distance of 0.30 meter beyond the outermost edge of the abutting living units.

A firewall shall be provided for duplex/single attached units and at every unit for rowhouses. No openings whatsoever shall be allowed except when the two abutting spaces of 2 adjacent living units are unenclosed or partially open, e.g. carports, terraces, patios, etc.; instead a separation wall shall be required. (See Figure 11 : Firewall for Dwelling Units on Property Line)

*gh*

*gh*

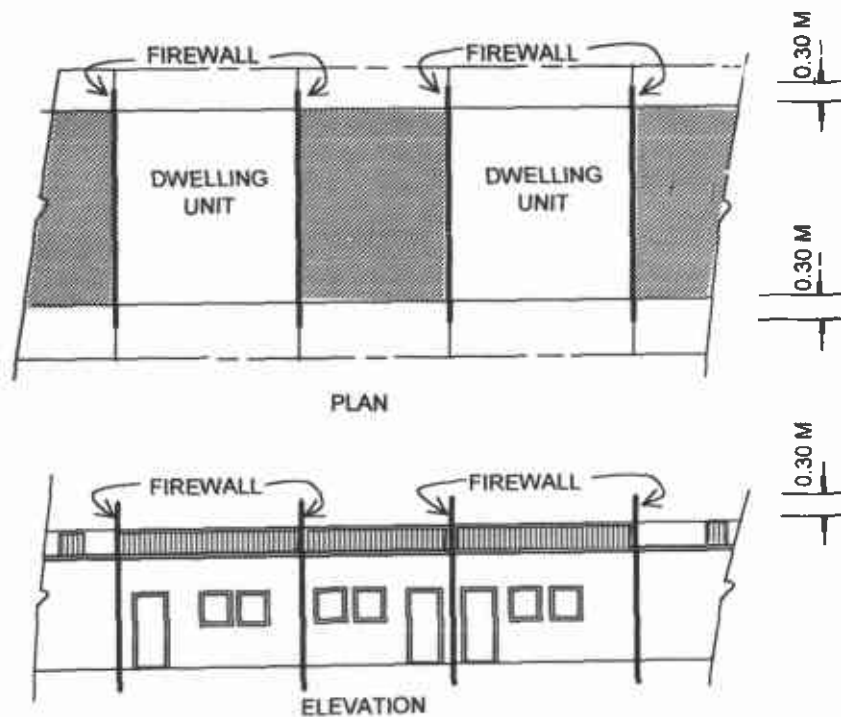

**Figure 11. Firewall for Dwelling Units on Property Line**

**B. Multi-Family Dwellings (Applicable for both Economic and Socialized Housing)**

**1. Lot Planning**

- a. **Access to the property.** Direct vehicular access to the property shall be provided by means of an abutting improved public street.
- b. **Access to the dwelling.** An independent means of access shall be provided to each dwelling, or group of dwellings in a single plot, without trespassing adjoining properties. Each dwelling must be capable of maintenance without trespassing adjoining units. Utilities and service facilities must be independent for each dwelling unit.

Each dwelling unit shall be provided with a sanitary means for the removal of garbage and trash.

- c. **Access to living units.** An independent means of access to each living unit shall be provided without passing through any yard of a living unit or any other yard.
- d. **Non-residential use.** Portions of the property may be designed for non-residential use provided the type of non-residential use is harmonious or

*GH*

*Room*

compatible with the residential character of the property. Some examples of allowable non-residential uses are private clinic/office, garages, carports.

NON - RESIDENTIAL AREAS > 25% OF TOTAL AREA

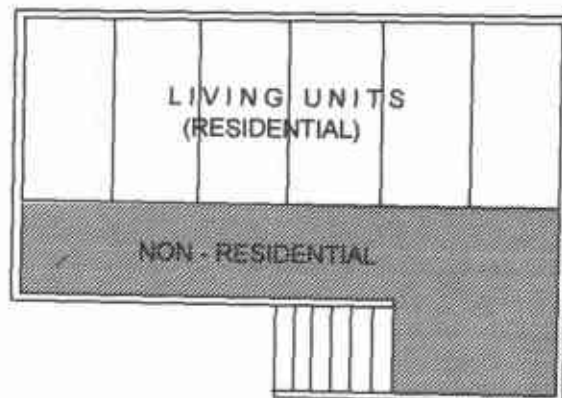

**Figure 12. Non - Residential Use**

- e. **Cooperative store, and structures for the homeowners' association.**

Any non-residential use of any portion of the property shall be subordinate to the residential use and character of the property. The floor area authorized for non-residential use, whether in the principal dwelling structure or in any accessory building, shall not exceed 25% of the total residential area.

The computation of the non-residential area shall include hallways, corridors or similar spaces which serve both residential and non-residential areas. (See Figure 12 : Non-Residential Use)

- f. **Open Space Requirements.** Portions of the property shall be devoted to open space to provide adequate light, ventilation and fire safety.

1. **Setbacks from the property line shall be maintained, the minimum of which shall be the following:**

**Table 11. Minimum Setbacks per Storey**

Kinds of Lot	Minimum Setback Requirement Per Storey										
	1&2	3	4	5	6	7	8	9	10	11	12
Interior	2.0	2.3	2.6	2.9	3.2	3.5	3.8	4.1	4.4	4.7	5.0
Inside											
Corner/Through											
Lot abutting 3 or more streets, alleys, rivers, esteros, etc.											

Handwritten initials/signature.

Handwritten signature.

2. Distance between building shall also be adequately maintained to ensure light and ventilation.

In general, the minimum distance between 2 buildings in which the taller buildings does not exceed 2 storeys shall be 4.0 meters. And the minimum horizontal clearance between the two roof eaves shall be 1.50 meters. (See Figure 13 : Distance Between 2 Storey Building)  
The minimum distance between two buildings wherein the taller building has 3 or 4 storeys, shall be 6.0 meters. And the minimum horizontal clearance between the two roof eaves shall be 2.0 meters. (See Figure 14 : Distance Between 3 Storey Building)

The minimum distance between buildings with more than 4 storeys shall be 10 meters. The minimum horizontal clearance shall be 6.0 meters.

Except, however, in cases when the two sides of the buildings facing each other are blank walls, i.e., either there are no openings or only minimal openings for comfort rooms, the minimum distance between the buildings shall be 2.0 meters. And the horizontal clearance between the roof eaves shall be 1.0 meter. (See Figure 15 : Distance Between Blank Walls of Two Buildings)

In the measurement of distance between two buildings, measurement shall be made where the distance between the two buildings is shortest. (See Figure 16 : Measurement of Distance Between Buildings)

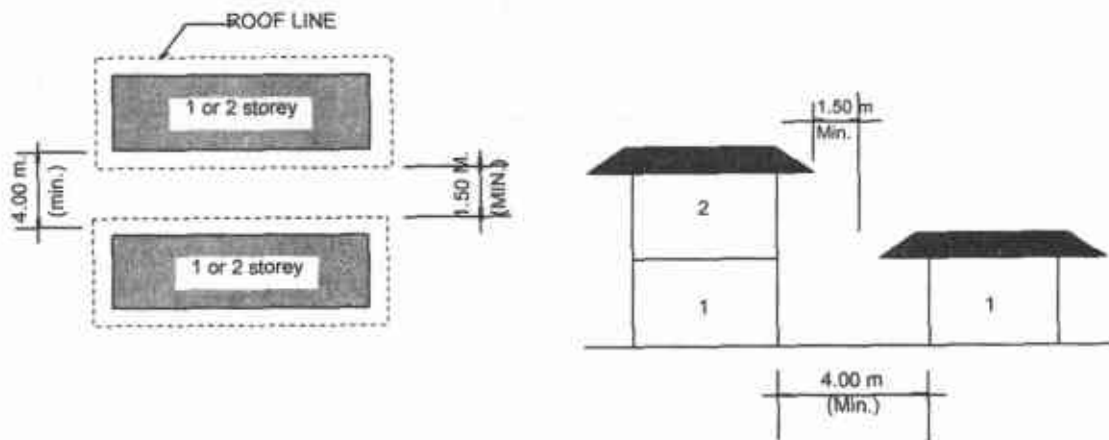

**Figure 13. Distance Between 2-Storey Building**

*g/nir*

*jam*

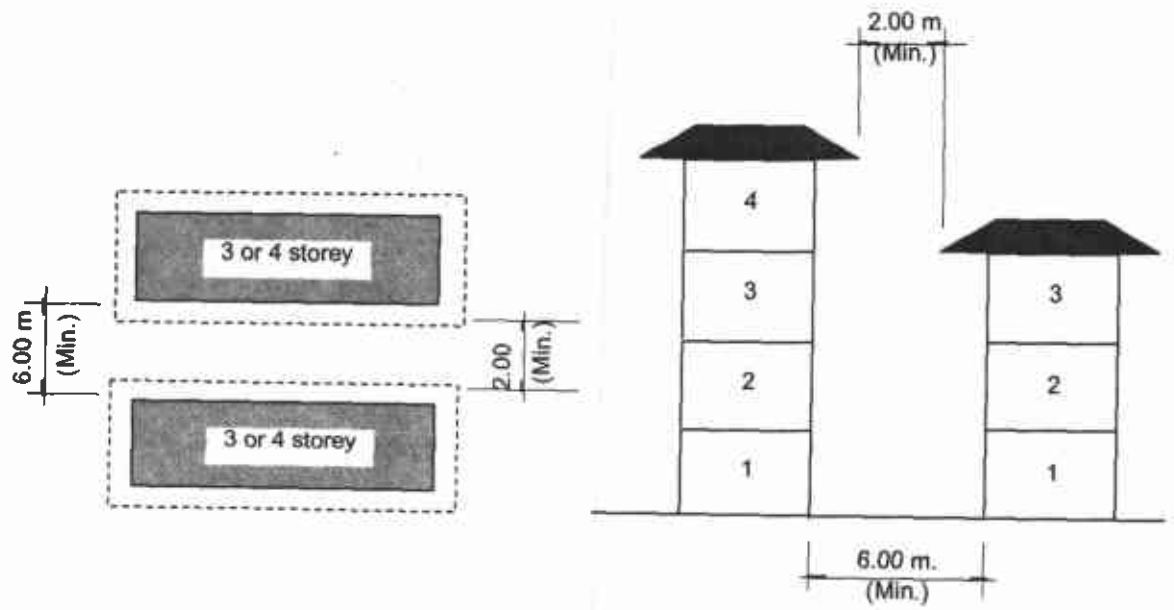

**Figure 14. Distance Between 3 - Storey Building**

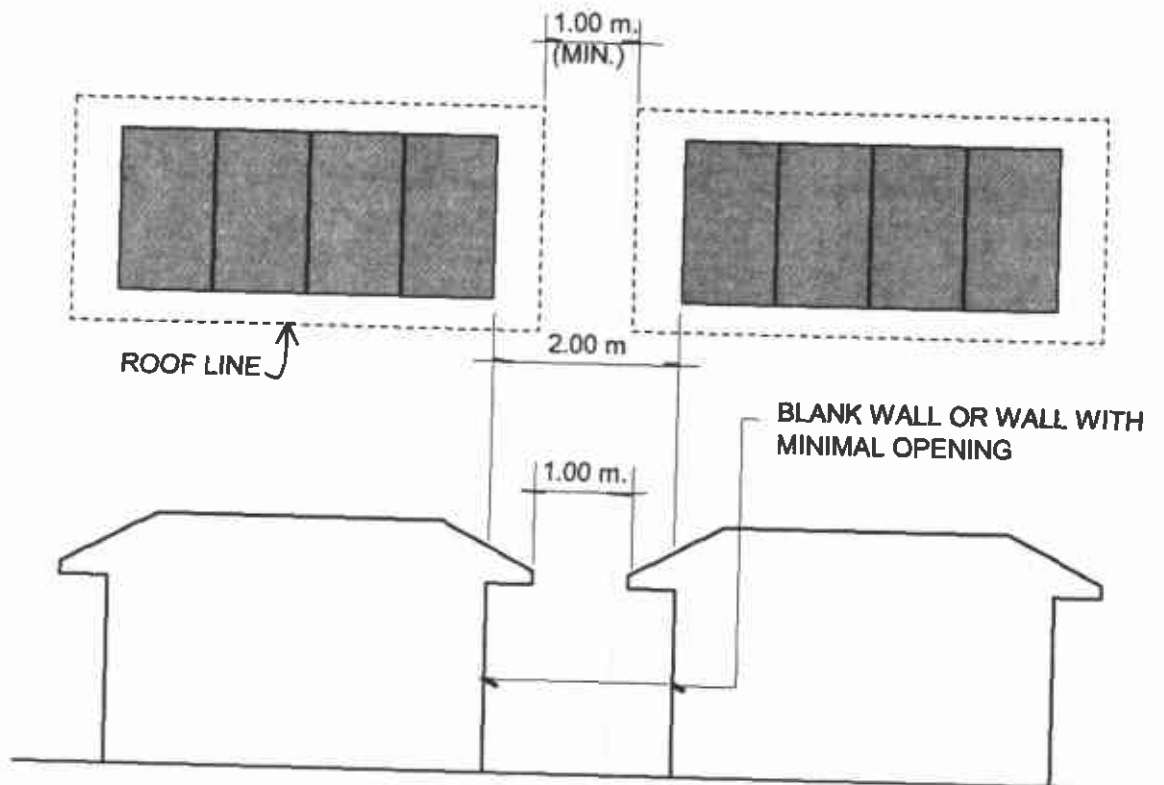

**Figure 15. Distance Between Blank Walls of Two Buildings**

*Handwritten mark*

*Handwritten signature*

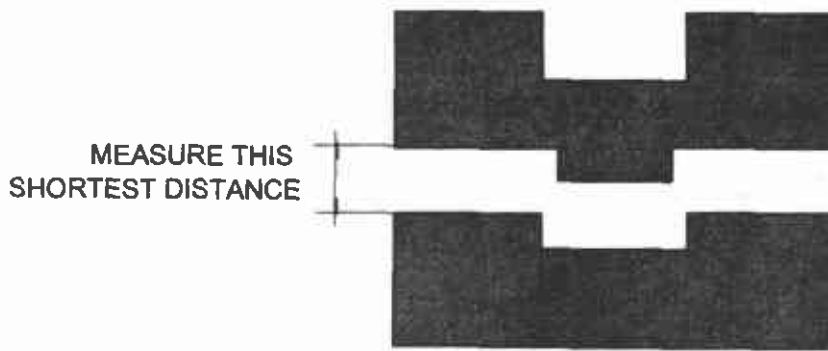

**Figure 16. Measurement of Distance Between Buildings**

- g. Parking Requirements.** For multi-family dwellings, the parking requirement shall be in accordance with the provisions of the National Building Code of the Philippines and its Implementing Rules and Regulations.

Off-site parking may be allowed in addition to the on-site parking provided that designated parking area is part of the project and provided further that it shall not be 100 meters away from the condominium project.

Mandatory compliance with additional parking space required by local ordinances.

## **2. Building Design Standards**

### **a. Living Units**

In general, all building design standards for the single-family dwelling shall apply for all living units of multi-family dwellings, except that, the minimum floor area of a living unit in multi-family dwellings shall be 22 square meters for economic housing and 18 square meters for socialized housing. Minimum floor area shall be in one floor level exclusive of mezzanine, if any. For BP 220 condominium projects, the minimum floor area shall be 18 square meters.

### **b. Exits, Corridors, Exterior Exit Balconies and Common Stairways**

Standards for exits, corridors, exterior exit balconies and common stairways shall conform with the provisions of the National Building Code of the Philippines, its Implementing Rules and Regulations as well as the Fire Code of the Philippines.

### **c. Utilities and Services**

To ensure healthful and livable conditions in the project, basic utilities and services shall be provided, the minimum requirements of which shall be:

*gh*

*Law*

### **c.1 Water Supply**

Water supply shall be potable and adequate in amount ; a main service connection and a piping system with communal faucets to serve the common areas like the garden, driveways, etc. shall be provided. Pipes branching out from the main water line shall service the individual units which shall be provided with individual water meters.

### **c.2 Power Supply/Electrical Service**

If available in the vicinity, a main power service shall be provided with a main circuit to service common lighting as well as common power needs of the dwellings. Like the water system, however, branch circuits with separate meters shall service the individual living units.

### **c.3 Drainage System**

Surface run-offs shall be channeled to appropriate repositories.

### **c.4 Sewage Disposal System**

Sewage disposal may be accomplished by any of the following means:

- a. discharge to an existing public sewerage system.
- b. treatment in a community disposal plant, or communal septic tank.
- c. Treatment in individual septic tanks with disposal by absorption field or leaching pit.

### **c.5 Garbage Disposal System**

Adequate services for the regular collection and disposal of garbage and rubbish in compliance with applicable local ordinances.

### **c.6 Elevator Requirements (If Applicable)**

Provision of elevators shall be in accordance with the requirements of the National Building Code of the Philippines. The same shall conform with the plans and specifications of the duly licensed design architect/engineer who shall determine the requirement for elevators including the number of cars, capacity, safety features and standards, elevator type, speed and location in relation to the over all design and use of the building. The design architect/engineer shall certify under oath that all components thereof are in accordance with the National Building Code of the Philippines, the Accessibility Law, National Industry Standards and other pertinent laws.(Approved as per Resolution No. 554, Series of 1994).

Compliance to the provisions of the Fire Code of the Philippines shall be mandatory.

### **3. General Construction Requirements**

#### **a. Structural Requirements**

All construction shall conform with the provisions of the latest edition of the Philippine Structural Code.

#### **b. Electrical Requirements**

All electric systems, equipment and installation shall conform with the provisions of the latest edition of the Philippine Electrical Code and the requirements of the electric utility that serves the locality.

#### **c. Sanitary Requirements**

All sanitary systems, equipment and installation shall conform with the provisions of the latest edition of Sanitation Code of the Philippines and its Implementing Rules and Regulations and National Plumbing Code.

#### **d. Construction Materials**

The use of indigenous materials for site development and construction of dwellings shall be encouraged, as long as these are in conformity with the requirements of these Rules and ensure a building life span of at least 25 years, or in correspondence to loan terms payment.

### **Section 7. Variances/Exemptions**

Variances from these standards and requirements may be granted pursuant to the conditions stipulated in Board Resolution No. R-97, series of 1982 (Annex A) under strict observance hereof will cause unnecessary hardship to the case of regional considerations/characteristics, peculiarities of the location and other relevant factors.

## **RULE III APPROVAL OF SUBDIVISION PLANS AND BUILDING DESIGNS**

### **Section 8. Approval Required**

No development of economic and socialized housing projects shall be allowed without having complied with the standards and approval procedures set forth in these Rules.

An approved socialized housing project shall not be upgraded to any other type of housing project.

*gfh*

*gfh*